Table of Contents

E85 Information and Communication Systems

Subject	Page
Information/Communication	5
Introduction	5
Radio Systems	5
Audio Systems	5
Telephone Systems	5
Navigation Systems	5
Radio and CD changer	6
New Features of the System	6
Components	7
BMW Business Radio-CD	7
BMW central information display radio (CID radio)	7
Central Information Display	9
Design of the central information display	9
CD Changer	10
BMW Aerial Systems	10
Rod Aerial	11
Aerial Diversity	11
Components	11
Rod Aerial	11
FM Aerial in Bumper	12
Aerial Diversity	12
Aerial Amplifier	12
Service Mode for Radios	13
Notes for Service	13
FM Aerial	13
Diagnosis	14
Coding	14
Car & Key Memory	14
Audio Systems	16
New Features	16
System Comparison - Sound Pressure	16
System Comparison -Linearity	17
Advantages of the Systems	17
Hi-Fi System	17
Hi-Fi Amplifier	17

Subject	Page
Speakers	18
Low-range Speakers (Woofers)	19
High-range Speakers (Tweeters)	19
Mid-range Speakers	19
Top Hi-Fi System	21
Top Hi-Fi Amplifier	21
Front Low-range Speaker (Woofers)	21
High-range Speakers (Tweeters)	21
Mid-range Speaker	22
Carver Woofers (Low-range Speakers), Rear	22
Carver Woofer Operating Principle	23
System Operation Top Hi-Fi	24
Top Hi-Fi with Radio Business-CD, or CID Radio	24
Principle of Operation	25
Hi-Fi Amplifier	25
Top Hi-Fi Amplifier	25
Improved Overall Acoustic Impression	26
Loudness	26
Speed-dependent Volume Control	26
Vehicle-specific Equalizing	26
Dynamic Equalizing	26
Dynamic Compression	26
Internal Temperature Monitoring	26
Notes for Service	26
Diagnosis	26
Coding	26
Car & Key Memory	26
Navigation	27
New Features	27
Advantages of New System	28
Components of System	28
Central Information Display	29
CID Control Panel	29
Navigation Computer DVD	29
GPS Aerial	30
Wheel Speed Sensor	30
Reverse Light Switch	30
Principle of Operation	31
More accurate calculation of arrival time	31
Improved Direction	31
Improved Map Presentation on the CID	31
New Map Presentations	32
Digitized Maps on DVD	32

Subject	Page
Operation	32
"Route Selection" Menu	33
Destination Input	33
New Route	33
Service Information	33
Conversion	33
Diagnosis	33
Service Mode	34
Accessing Service Mode	34

E85 Information and Communication Systems

Model: E85

Production: From Start of Production

OBJECTIVES

After completion of this module you will be able to:

- Understand the operation E85 Audio Systems
- Perform Radio and Navigation Service Modes
- Locate and Identify E85 Audio System Components
- Understand the Operation of the E85 Navigation System

Information/Communication

Introduction

The E85 has soared to be the new dynamic leader in the market segment of premium roadsters. Its breathtaking design and even sportier handling place it distinctly higher than the E36/7.

In keeping with its top-of-the-range status, the Z4 offers new features in the field of information and communication systems.

Radio Systems

The radios have been redesigned and equipped with a CD drive in line with the vehicle's premium status. It features a new central information display radio specifically designed for the menu in the central information display.



Audio Systems

In addition to the "Hi-Fi" audio systems, a "Top Hi-Fi" system is offered in the Z4. This system satisfies the most demanding requirements with regard to sound quality and sound impression. This is achieved by the use of Carver low-range speakers or woofers. This new speaker technology enables high sound pressures and distortion-free basses in conjunction with compact speaker dimensions.

Telephone Systems

At this time No factory installed phone systems are available in the Z4.

Navigation Systems

A further highlight is the high navigation system. The Z4 is the first BMW roadster equipped with a display for presenting maps for the navigation system. The navigation information is shown on a central information display located in the middle of the instrument panel. The central information display features a folding function and is folded away neatly in the instrument cluster when not in use.

Radio and CD changer

The following radios are available for the E85:

- BMW Business radio-CD
- BMW central information display radio CID radio

All radios are new generation radios (NG radios). The radios feature a K-Bus connection via which they communicate with other control units.



The AF input (audio signals) of the CD changer was increased from 0.5 V to 2.0 V in order to increase the signal-to-noise ratio. The new generation radios detect whether they communicate with a 0.5 V CD changer (old) or a 2.0 V CD changer (new) and switch over the input accordingly.

A 6-CD changer is additionally available. A radio with a cassette drive is no longer available for the E85.

Central Information Radio-CD (CID)



Standard Business Radio-CD



New Features of the System

The central information display radio is a new feature on the E85 and serves as the control panel for the CID. The CID radio combines the radio functions with operation of the navigation system, on-board computer, DSP amplifier, settings as well as deactivation of the CID.

Components

The radios can be optionally fitted at the factory in the following combinations:

- BMW Business Radio-CD
- BMW Central Information Display Radio (CID Radio)

BMW Business Radio-CD

The BMW Business radio-CD can be ordered together with the Hi-Fi or Top Hi-Fi system. A CD changer can be additionally connected. In connection with the Hi-Fi audio system, the BMW Business radio-CD is the standard unit in the US.

The BMW Business radio-CD is a world radio and can be coded for the different regions. The Business radio-CD is the basic radio in the US version. The radio functions correspond to the previous BMW Business radio. The only difference is in the drive. The radio is now equipped with a CD drive. The BMW Business radio-CD features aerial diversity.

In the system network, the BMW Business radio-CD facilitates the display and control of following components:

- CD changer
- Settings for Hi-Fi and Top Hi-Fi
- AUX socket if fitted (option for auxiliary inputs such as MP3 players)



BMW central information display radio (CID radio)

The CID radio is the control panel for the central information display. The CID is the High navigation system. The CID radio is offered together with a CD. The CID radio can be ordered together with the Hi-Fi or Top Hi-Fi system. A CD changer can be additionally connected.

The central information display radio is offered worldwide as the display and operating unit for the High navigation system. The CID radio consists of the control panel with the radio functions in the center console and the central information display in the instrument panel.

The CID radio features a CD drive. A CD changer can be ordered additionally. The CID radio features aerial diversity.

In the system network, the central information radio facilitates the display and control of following components:

- Central information display (CID)
- Navigation computer
- CD changer
- Settings for Hi-Fi and Top Hi-Fi
- On-board computer functions
- AUX socket if fitted (option for auxiliary inputs such as MP3 players)

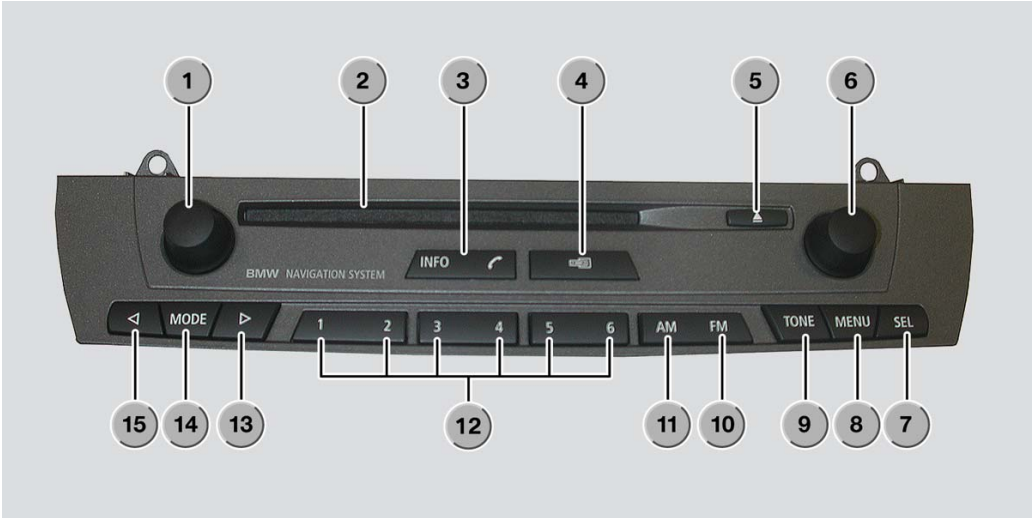

Index	Explanation	Index	Explanation
1	ON/OFF Volume Control	9	Button for Sound Settings
2	CD Compartment	10	FM Button
3	Telephone Acceptance/Info Button	11	AM Button
4	Selector Button for Audio/Last Menu	12	Station Memory Buttons
5	CD Eject Button	13	Forward Scan
6	Push-button/Rotary Knob	14	Mode Button
7	SEL Button	15	Backward Scan
8	Menu Button		

Central Information Display

The central information display is located in the center of the instrument panel above the ventilation outlet.

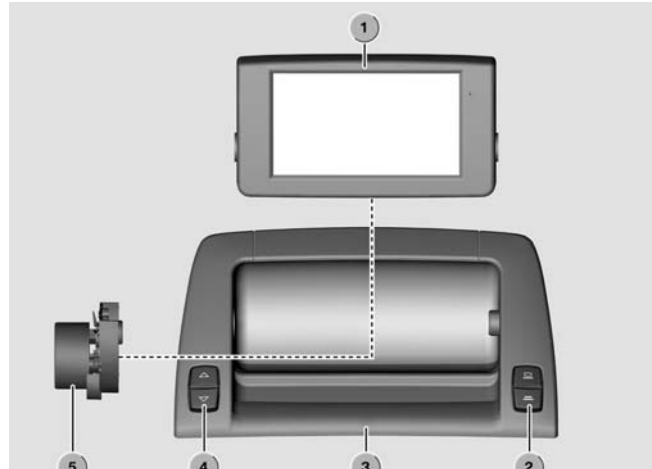

Index	Explanation	Index	Explanation
1	Screen	4	Switch for Fine Adjustments
2	Switch for Opening/Closing	5	Stepper Motor with Gear Mechanism
3	Mounting		

Design of the central information display

The central information display (CID) includes the following components: advanced TFT display, crossed-coil motor and mounting with switches.

- Advanced TFT display** - The LC display is designed as a 6.5" advanced TFT display. The display is of identical design as the 6.5" display of the on-board monitor in the E46. The advanced TFT display adapts automatically to the brightness of the ambient light. The display has a visible range of 144 mm x 79.5 mm and a resolution of 400 x 240 Pixels. The display is an analog unit and is controlled by RGB signals.
The display is mounted such that it can rotate and is moved by a crossed-coil motor.
- Crossed-coil motor with gear mechanism (Stepper Motor)** - The crossed-coil motor is a brushless DC motor. The positions of the display are detected by Hall sensors on the gear mechanism.
- Mounting** - The display and the crossed-coil motor are accommodated in a mounting. The mounting is located in the center of the instrument panel so that the same component can be used for left-hand drive and right-hand drive vehicles. The mounting is screwed flush with the surface of the instrument panel.
- Switch** - Left and right switches are integrated in the trough. The left switches serves the purpose of finely setting the display to improve the readability corresponding to the seat position and light conditions. The right switch serves to fold the display in and out.

When raised, the position is between 35-108 degrees. The position last stored (last function memory position) is raised. The display can now be finely adjusted in steps (1 step = 1.2 degrees) using the left-hand switch. The signal from the switch is sent directly to the stepper motor and is not transferred via the K-Bus.

Manual fine adjustment of the display is also possible in a range from 35-108 degrees. In an area below this range (< 35 degrees), the CID is closed automatically as it can no longer be read effectively in this position. The right-hand switch can be used to close the display.

Navigation directions are not interrupted if the display is closed while the navigation system is active. When terminal R is switched off, the CID is always closed and the last position stored. The display can be switched off by means of a button in the main menu.

If the display is closed manually or electrically while driving, the display will remain closed at the start of the next trip (last function memory position). The display must first be raised again by pressing the switch.

CD Changer

The optional CD changer is the same 6-CD changer as fitted on the E46. The CD changer is adapted to the new generation radios and features a 2.0 V AF output.

The CD changer is located in the lockable compartment in the center of the partition. The compartment is locked with the central locking system.

BMW Aerial Systems

The radio aerials for AM/FM are described in the following. The other aerials are described in the respective chapters.

The E85 features the following aerial systems:

- Rod aerial for AM/FM
- FM aerial in rear bumper
- GPS aerial for navigation system



Rod Aerial

The rod aerial is a common part from the E46 convertible. The aerial is designed for AM/FM reception and additionally features an integrated telephone aerial.

The rod aerial is mounted on the rear left side panel. The aerial amplifier is screwed to the aerial from below.

The rod aerial consists of the aerial rod, aerial head and aerial base with integrated aerial amplifier.

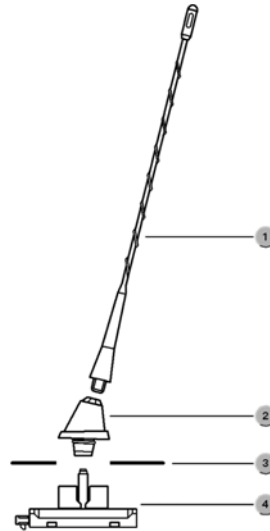

1. Aerial Rod
2. Aerial Head
3. Body Panel
4. Aerial Amplifier

Aerial Diversity

The E85 features aerial diversity for the higher grade radios. Aerial diversity comprises following components:

- Rod aerial with amplifier
- FM aerial in bumper
- FM aerial amplifier
- Aerial diversity

The aerial amplifier and aerial diversity are fitted in the rear left of the luggage compartment. The second FM aerial is located on the rear left in the bumper.

Components

The aerial diversity system includes the rod aerial with amplifier and the FM aerial in the bumper.

Rod Aerial

The rod aerial is identical to that of the E46 convertible. The rod aerial is designed for the following wavebands: AM 522 kHz - 1710 kHz and FM 87.5 MHz - 108 MHz.

FM Aerial in Bumper

The FM aerial consists of a 73 cm long line. The FM aerial is mounted in the bumper on adjustable clips. The FM aerial is adapted precisely to the vehicle. For this reason, no changes must be made to the aerial. The FM aerial is connected to an aerial amplifier.



Aerial Diversity

In the E85, 2 physical aerials are connected to the radio aerial diversity, i.e. the rod aerial and the aerial in the bumper. The aerial diversity function switches over to another aerial as soon as the system undershoots a defined threshold. Changeover takes place in such a way that no interruption can be heard. Depending on the reception situation, reception on both aerials simultaneously is also possible.

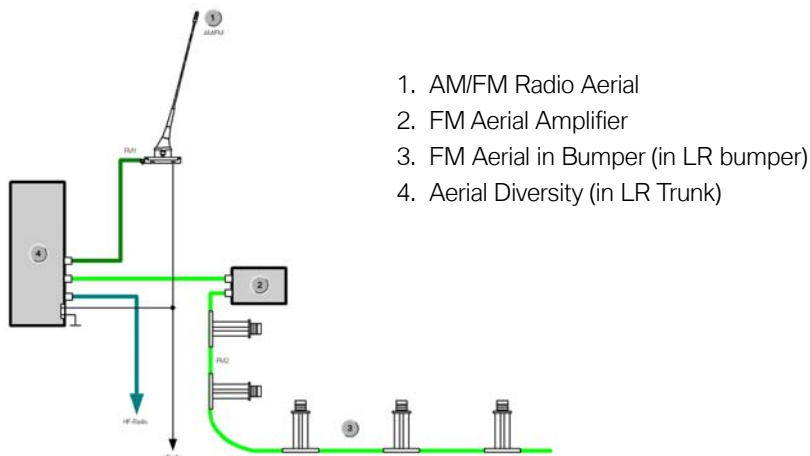

Aerial Amplifier

The aerial amplifier is designed for FM reception. The aerial amplifier is connected to the aerial diversity by means of a coaxial cable.



Service Mode for Radios

Service mode is used for a quick check of the most important radio functions. In the event of a customer complaint or malfunction, several important functions can be checked directly at the radio with the aid of the service function. It is necessary to access service mode for this purpose.

Service Mode for Business-CD

- Switch on radio
- Press the "m" button within 8 seconds and hold for at least 8 seconds
- The functions listed in the following table are now possible via the service menu
- Switch off the radio to exit service mode

Service Mode for Radios CID

- Switch on radio
- Press the "SEL" button within 8 seconds and hold for at least 8 seconds
- The functions listed in the following table are now possible via the service menu
- Switch off the radio to exit service mode

Menu	Screen Contents	Explanation
Serial Number	X1001035	Serial number of Device
Software Version	37-99 30	Software Status WW/YY version
GAL	1-6	Stage of speed dependent volume adjustable with station buttons.
FM	Frequency Station Identifier F... Q... D210	Frequency of station Station identifier being received Field Strength Quality of Station RDS Identifier
DSP	0	Whether vehicle is equipped with DSP 1=DSP
TP Volume	0	Not used in USA
AF (Alternate Frequencies)	Auto	Not used in USA
Area	USA	2 = USA
Index	03	Revision Index

Notes for Service

FM Aerial

The FM aerial must be checked in the event of damage to the bumper (accident). The aerial line must neither be shortened nor lengthened.

The correct position of the spacers for the aerial must be ensured. The aerial is matched to the metallic body structure. Changes to the body structure greatly influence the aerial function.

Diagnosis

Diagnosis of the radio without CID comprises the following:

- Read identification
- Read fault code memory
- Delete fault code memory
- Activate components, e.g. button functions, individual channels
- Diagnosis query, e.g. field strength, setting of speed dependent volume control

Coding

Coding in the radio comprises the following functions:

- New coding (country-specific functions)
- Retrofitting
- Conversion

Car & Key Memory

The following functions can be stored in the car & key memory:

- Sound settings
- Audio source
- The last station is stored

Notes:



Classroom Exercise - Review Questions

1. What are the 2 audio system offered in the E85?

2. In the event of a customer complaint regarding radio reception issues, what are some of the steps in diagnosing this complaint?

3. Where are the FM aerials located on the E85?

4. What are the two radios offered on the E85?

Audio Systems

The following audio systems are available for the E85:

- Hi-Fi audio system
- Top Hi-Fi audio system

New Features

For the first time at BMW, binding audio standards have been defined for the E85 which will also be adopted in successor models. In addition to the minimum requirements relating to the systems, Carver speaker technology is used for the first time worldwide in a motor vehicle (Top Hi-Fi audio system). This system achieves substantial improvements in the low frequency range.

The audio standards stipulate the following requirements:

- Classification in 2 audio systems: Hi-Fi and Top Hi-Fi
- Symmetry of sound field: All systems ensure uniform distribution of the sound field in the vehicle and convey the overall acoustic impression that the source of the music is in front of the driver and passenger.
- Sound pressure
- Linearity of stereo signal

With the aid of the Carver speaker technology, high sound pressures can be achieved although there is only a low resonance volume (space behind the speakers) available in the roadster.

System Comparison - Sound Pressure

The sound pressure in the vehicle is the measure for establishing the total volume up to which distortion-free sound reproduction is possible.

The higher the sound pressure the greater the volume. When the sound pressure is increased by approximately 10 dB, the volume is subjectively doubled.

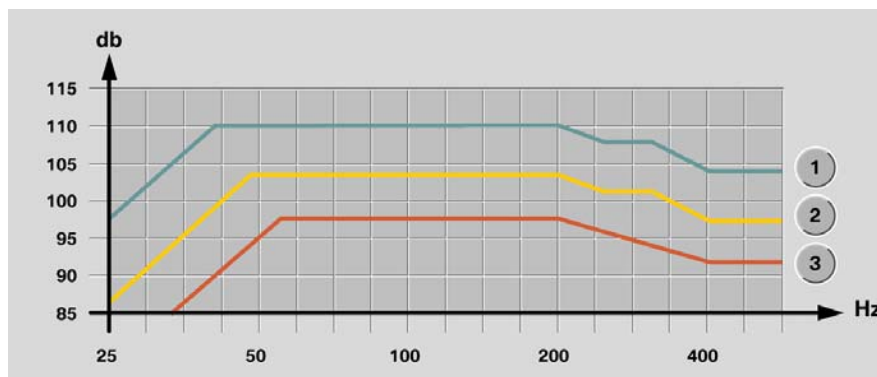

1. Top Hi-Fi
2. Hi-Fi
3. Stereo (not in US)

System Comparison -Linearity

A frequency response as linear as possible is the prerequisite for sound reproduction true to the original.

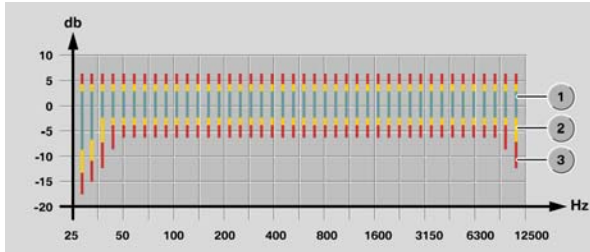

1. Top Hi-Fi
2. Hi-Fi
3. Stereo (not in US)

Advantages of the Systems

The following advantages characterize the 2 new audio systems:

- Compared to the E36/7, distinct improvements in the low frequency range have been achieved.
- Due to the dynamically set parameters (adaptive filters) of the Top Hi-Fi amplifier, the sound impression is adapted to the driving noise characteristic of a roadster.
- The Hi-Fi and Top Hi-Fi audio systems can be combined with virtually all radios.

Hi-Fi System

The Hi-Fi audio system consists of following components:

- Radio Business-CD or CID
- Hi-Fi amplifier
- Front left and right low-range speakers (woofers)
- Front left and right high-range speakers (tweeters)
- Front left and right mid-range speakers
- Rear left and right low-range speakers (woofers)
- Rear left and right mid-range speakers
- CD changer (optional)

Hi-Fi Amplifier

The Hi-Fi amplifier is designed as an analogue 10-channel amplifier. The 4 input channels are divided via frequency gates and equalizing filters over 10 channels. The Hi-Fi amplifier is installed in the luggage compartment trough next to the vehicle battery.

The output power is:

- Low-range 4x40 W
- High range/mid-range 6x25 W

The channels are divided over a 3-way speaker system at the front and a 2-way speaker system at the rear.

Speakers



Index	Explanation	Index	Explanation
1	Radio	5	CD Changer (optional)
2	Low-range speaker, front	6	Low-range speaker, rear
3	High-range speaker, front	7	Mid-range speaker, rear
4	Mid-range speaker, front	8	Hi-fi amplifier

Low-range Speakers (Woofers)

The front woofers (low-range speakers) are mounted at the bottom in the A-pillars on the left and right. The woofers are arranged transversely with respect to forward direction. The resonance volume is approximately 10 l and utilizes a part of the sill area. Rear woofers are additionally installed in the partition behind the seats.

High-range Speakers (Tweeters)

The tweeter has a diameter of 26 mm and has a fabric cap. The maximum load capacity is 25 W. The tweeter (high-range speaker) covers a frequency range from 4000 Hz to 20,000 Hz. The tweeter is connected to the woofer.

The frequency range of the high-range speaker is set by means of a capacitor.

The tweeter (high-range speaker) is located in a panel mounted in the mirror triangle.

The output direction of the tweeter is directed at the head area of the occupant opposite. The tweeter (high-range speaker) is based on a sealed design.

Mid-range Speakers

The mid-range speakers have a diameter of 100 mm and a paper cone. The maximum load capacity is 25 W. The mid-range speaker covers a frequency range from 100 Hz to 15,000 Hz. The front and rear mid-range speakers are of identical design.

The front mid-range speakers are fitted in the doors. The rear mid-range speakers are mounted behind the seats. The front mid-range speakers emit sound transversely with respect to forward direction. The mid-range speakers utilize the resonance volume of the doors. The output of the rear mid-range speakers is aligned in forward direction. The resonance volume is approximately 2 liters.



1. Rear Mid-Range Speaker
2. Rear Woofers

Hi-Fi System Overview

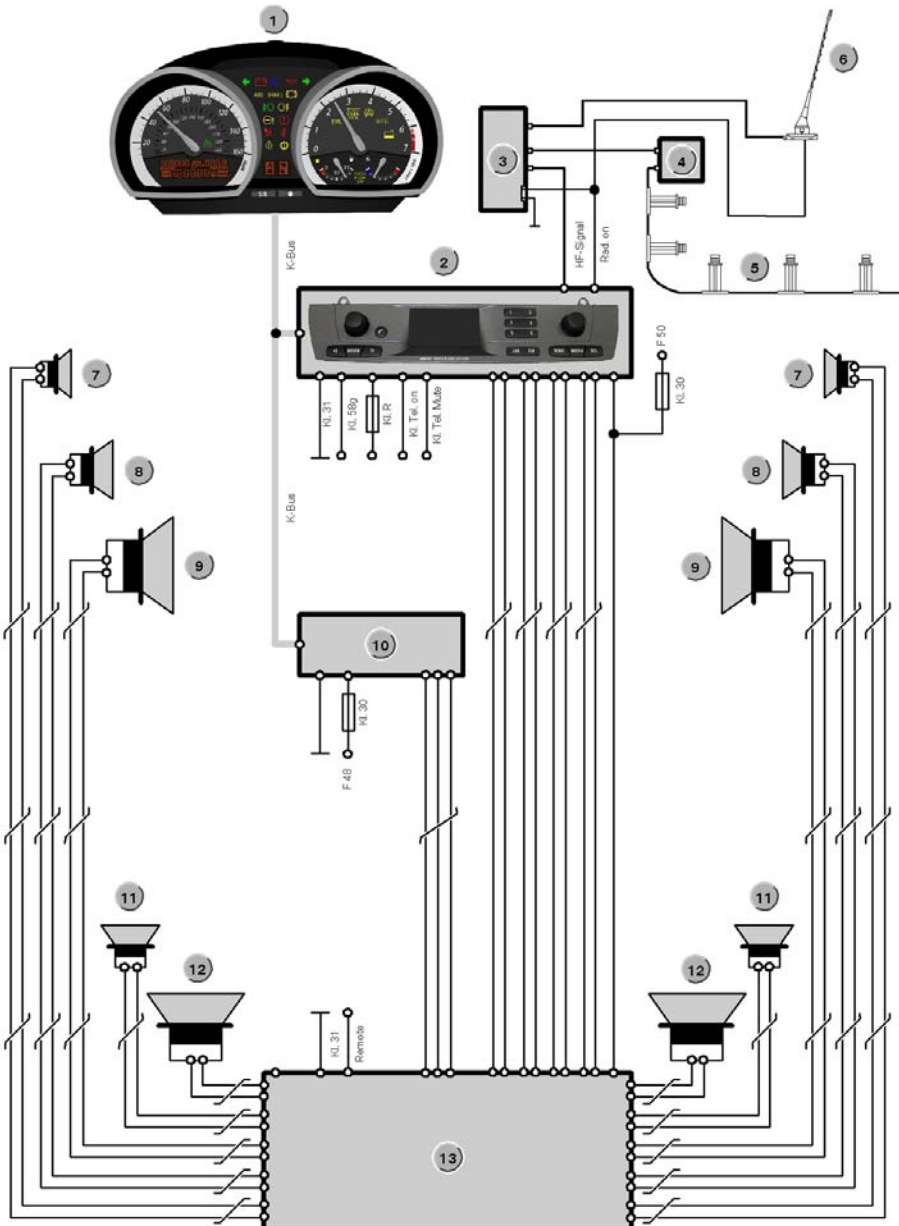

Index	Explanation	Index	Explanation
1	Instrument Cluster	8	Mid-Range Speaker Front
2	Radio	9	Low-Range Speaker Front
3	FM Aerial Diversity	10	CD Changer
4	FM Amplifier	11	Mid-Range Speaker Rear
5	FM Aerial #2	12	Low-Range Speaker Rear
6	AM/FM Aerial #1	13	Hi-Fi Amplifier
7	High-Range Speaker Front		

Top Hi-Fi System

The Top Hi-Fi audio system consists of following components:

- Radio Business-CD or CID
- Top Hi-Fi amplifier
- Front left and right low-range speakers (woofers)
- Front left and right high-range speakers (tweeters)
- Front left and right mid-range speakers
- Rear left and right mid-range speakers
- Rear left and right low-range speakers (woofers) in Carver technology
- CD changer (optional)

Top Hi-Fi Amplifier

With regard to its functionality, the Top Hi-Fi amplifier corresponds to the previous DSP amplifier as already used in other model series. The special features on the E85 are the two high voltage output stages (30 V) for the Carver woofers.

The Top Hi-Fi amplifier has 2 analogue inputs (left and right). In addition, the Top Hi-Fi amplifier features a digital input for the CD changer connection (coaxial cable). This arrangement achieves a higher signal quality.

The Top Hi-Fi amplifier is installed in the luggage compartment next to the vehicle battery.



Front Low-range Speaker (Woofers)

The woofer has a diameter of 160 mm and a paper cone. The maximum load capacity is 50 W. The woofers (low-range speakers) cover a frequency range from 50 Hz to 500 Hz.

The front woofers (low-range speakers) are mounted at the bottom in the A-pillars on the left and right.

High-range Speakers (Tweeters)

The tweeter has a diameter of 26 mm and a fabric cap or calotte. The maximum load capacity is 25 W. The tweeter (high-range speaker) covers a frequency range from 4000 Hz to 20,000 Hz.

The frequency range of the high-range speaker is set by means of a capacitor.

The tweeter (high-range speaker) is located in a panel mounted in the mirror triangle. The output direction of the tweeter is directed at the head area of the occupant opposite. The tweeter (high-range speaker) is based on a sealed design.

Mid-range Speaker

The mid-range speaker has a diameter of 100 mm and an aluminum cone. The maximum load capacity is 50 W. The mid-range speaker covers a frequency range from 100 Hz to 10,000 Hz. The front and rear mid-range speakers are identical.

The front mid-range speakers are fitted in the doors. The rear mid-range speakers are installed in the partition behind the seats.

Carver Woofers (Low-range Speakers), Rear

The Carver woofers have a diameter of 160 mm and a paper cone in Carver technology. The maximum load capacity is 100 W. The Carver woofers cover a frequency range from 30 Hz to 150 Hz.

The rear Carver woofers are accommodated in the partition behind the seats, the resonance volume is approximately 10 liters.

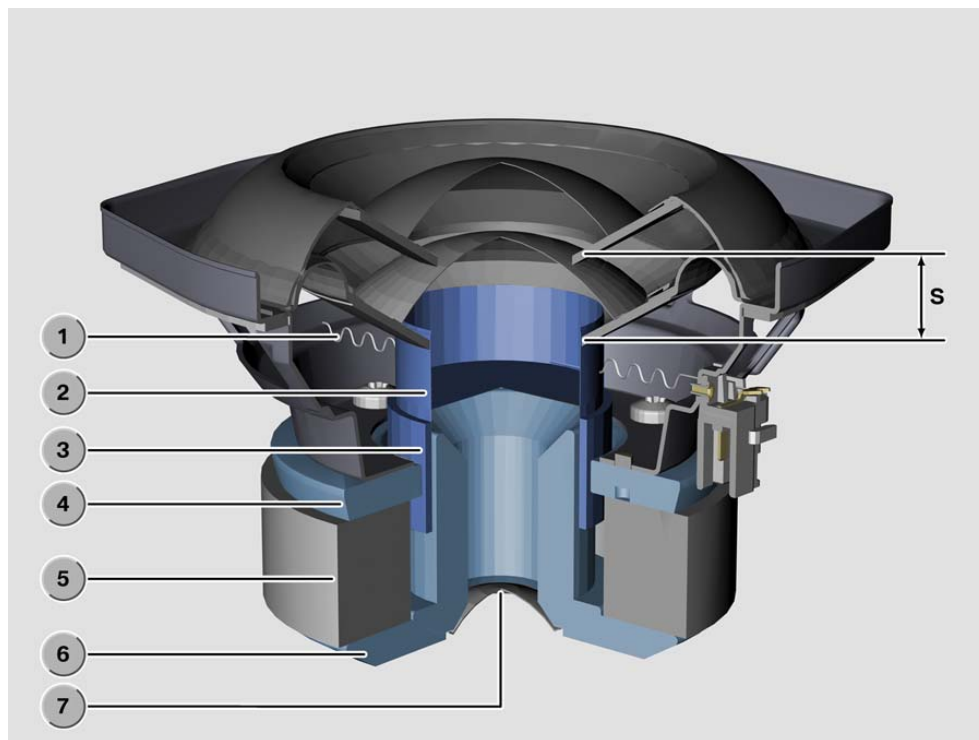

Index	Explanation	Index	Explanation
1	Centering Swing Arm	5	Permanent Magnet
2	Displacement Cylinder	6	Iron Core
3	Moving Coil	7	Ventilation Hole
4	Pole Core	8	Diaphragm Displacement

Carver Woofer Operating Principle

High sound pressure is required for achieving a rich bass. The Carver woofers (low-range speakers) produce this sound pressure with their small diameter by increasing the displacement of the diaphragm. The sound pressure is produced by movement in the volume of air.

The volume of air moved is derived from the diaphragm area multiplied by the displacement. To date to achieve this, the largest possible diaphragm area (diameter of the speaker) was used in conjunction with relatively low displacement (approximately. 3-10 mm). A matching resonance volume is additionally required.

In vehicle construction applications, this technology leads to a conflict between vehicle design and vehicle equipment: Due to the design and comprehensive level of equipment, there is little package space available for large bass speakers.

Carver technology represents a new approach in solving this problem. Thanks to Carver technology, a high sound pressure is produced with a small speaker diameter by increasing the diaphragm displacement (approximately. 30 mm).

Due to the greater diaphragm displacement Carver woofers (low-range speakers) require a higher voltage supply than conventional speakers.

A special DSP amplifier with high voltage output stages (30 Vrms) is required for the Top Hi-Fi audio system. It is necessary to greatly increase the magnetic force in order to achieve greater diaphragm displacement. The solenoid was adapted accordingly. A high magnetic force also means that a high back emf is produced in the solenoid (back emf $U_{emf}=B.l.v$).

The back emf counteracts the output voltage of the amplifier thus reducing the effective voltage at the solenoid.

It is not possible to operate Carver speakers with the amplifiers (radio output stages 6 Vrms) previously used.

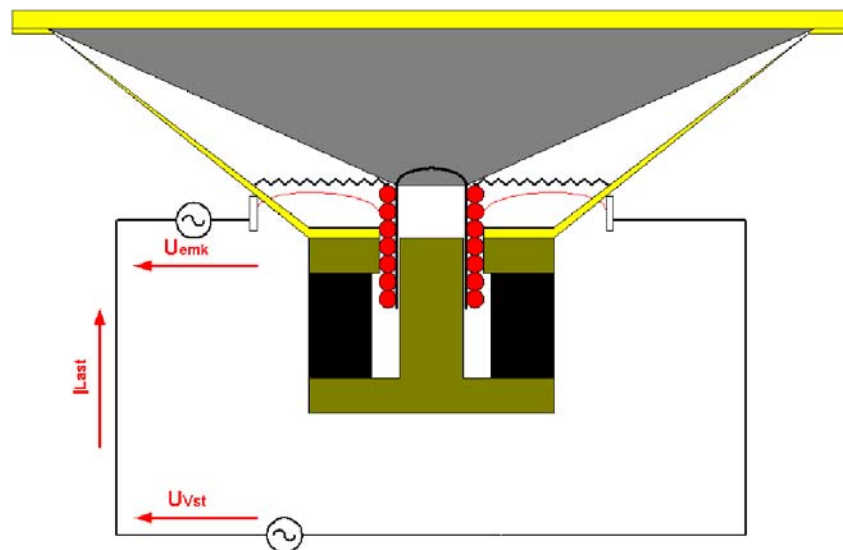

System Operation Top Hi-Fi

The Top Hi-Fi audio system features a 10-channel analogue amplifier with DSP technology as used in the current vehicles. The Top Hi-Fi amplifier is controlled with a constant audio signal via the two analogue output channels of the radio. In addition, the Top Hi-Fi amplifier features a digital input for the CD changer. The speakers are connected to the 10 output channels.

The Top Hi-Fi audio system has following output ratings:

- Medium-range and high-range speakers: 6x20 W
- Low-range speakers: 2x40 W
- Carver low-range speakers: 2x100 W

Top Hi-Fi with Radio Business-CD, or CID Radio

Depending on the type of radio installed, programmed sound settings can be selected or freely programmed. In connection with the radio Business-CD, one of the following 3 programmed sound settings can be selected in the "Tone" (sounds) menu:

- Jazz
- Hall
- Cathedral

The radio CID radio with the central information display offers the following features:

- 3 preset menus (see above)
- 3 freely programmable menus

In the case of the CID radio, the overall acoustics can be set individually by means of a 7-band graphic equalizer.

Principle of Operation

All audio systems are controlled via the radio. The differences between the systems are in the control of the amplifiers. The Hi-Fi and Top Hi-Fi amplifiers do not feature direct control functions.

Hi-Fi Amplifier

The Hi-Fi amplifier is controlled via the radio.

The required settings are selected in the radio and output via 4 radio outputs to the amplifier. The amplifier amplifies the settings and distributes them over 10 channels.

No variable matching takes place in the Hi-Fi amplifier. Vehicle-specific equalizing is integrated in the Hi-Fi amplifier.

The following functions can be set in the radio:

- Volume
- Bass
- Treble
- Balance (left/right)
- Fader (front/rear)
- Loudness
- Speed-dependent volume control

Top Hi-Fi Amplifier

The Top Hi-Fi amplifier is also controlled via the radio. The Top Hi-Fi amplifier receives a constant audio signal for the left and right (via the two audio inputs) from the radio. The required settings are transferred via the K-Bus and formed in the amplifier.

The following functions can be set:

- Volume
- Bass
- Treble
- Balance (left/right)
- Fader (front/rear)

In addition, the overall acoustics can be set individually (CID only) by means of a 7-band graphic equalizer.

Improved Overall Acoustic Impression

With the aid of software, adaptations were implemented in the Top Hi-Fi amplifier for the purpose of improving the overall acoustic impression.

The following adaptations in the amplifier are conducted automatically:

- Loudness
- Speed-dependent volume control
- Vehicle-specific equalizing
- Dynamic equalizing
- Dynamic compression
- Internal temperature monitoring

Loudness

To improve the listening nuance, the low frequencies are raised slightly at low volume settings.

Speed-dependent Volume Control

The volume is raised as the driving speed increases. 6 characteristic curves are available for this purpose. The characteristics can be set individually in the service functions.

Vehicle-specific Equalizing

The acoustics are matched to the vehicle interior.

Dynamic Equalizing

The acoustics are adapted to increasing driving noise.

Dynamic Compression

The dynamics must be compressed to avoid overloading the system. The upper level of effective dynamics is limited by the output power of the amplifier and the load capacity of the speakers. For this reason, the speed-dependent volume cannot be increased infinitely,

Internal Temperature Monitoring

In the event of excessively high temperature, the output of the output stages is reduced in order to cool them. The temperature of the output stages is permanently monitored.

Notes for Service

Diagnosis

No diagnosis functions are provided for the audio systems.

Coding

No variant coding functions are provided for the audio systems.

Car & Key Memory

No functions are available for the car & key memory.

Navigation

New Features

For the first time for a roadster, a High version navigation system with map presentation on a display has been developed for the E85.

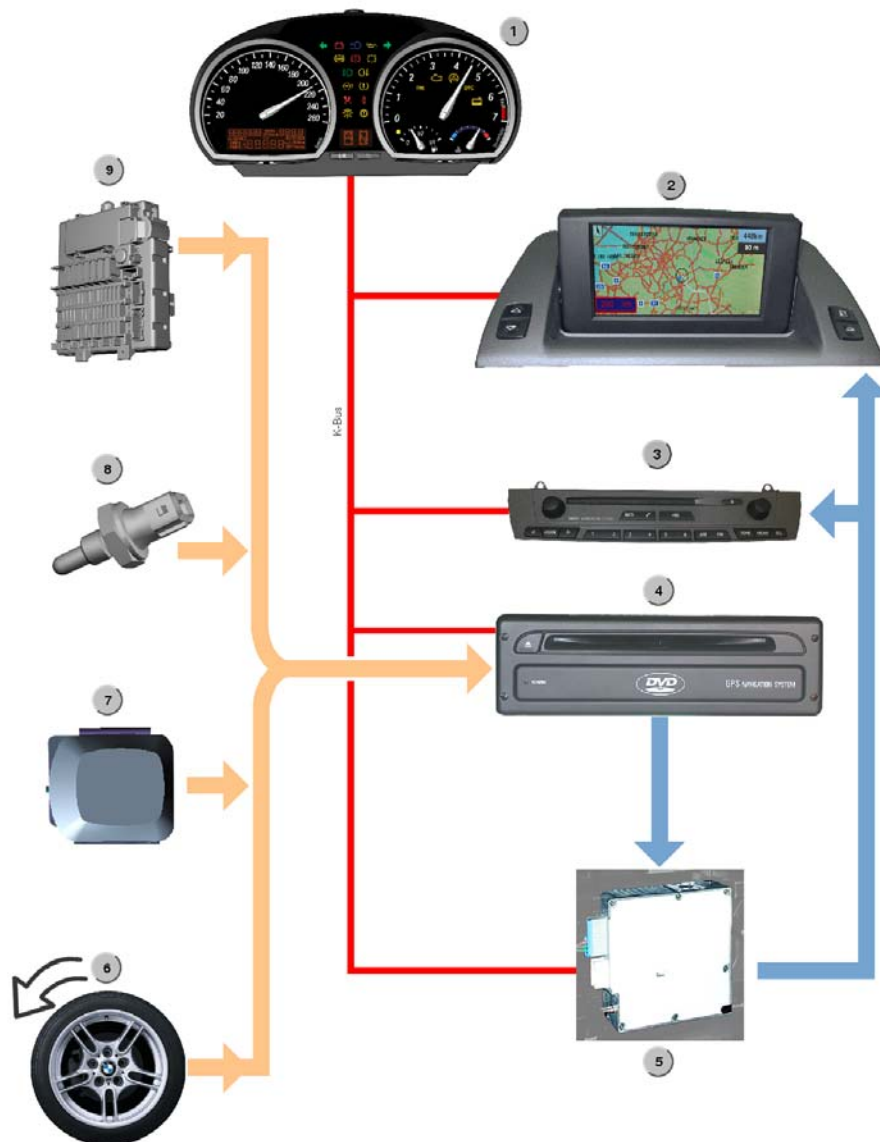

Index	Explanation	Index	Explanation
1	Instrument Cluster	6	Wheel Speed Signal
2	Central Information Display (CID)	7	GPS Aerial
3	CID Control Panel (radio)	8	Reverse Light Switch
4	Navigation Computer (DVD)	9	Fuse box
5	Video Module		

The navigation system of the E85 is based on the familiar MK-3 navigation system. The navigation computer has been further developed and optimized for the E85 and is now known as navigation computer DVD.

The specific features of the new system include:

- DVD drive
- Faster processor
- Larger memory

Advantages of New System

- Map presentation for navigation in the Z4 roadster
- The use of the DVD drive now facilitates presentation of all of the USA on one DVD
- Extended destination entry functions
- More accurate calculation of arrival time
- Improved route planning
- More exact traffic control management
- New display presentation
- Data on CD or DVD

Components of System

The High navigation system consists of following components:

- Central information display CID
- CID control panel
- Navigation computer DVD
- GPS aerial
- Wheel speed sensor
- Reversing light switch
- Video module

Central Information Display

The central information display is the display unit for the High navigation system. The display is designed as a 6.5" advanced TFT display for presenting the operating interface and maps.

To optimize the legibility, the display can be precision adjusted by means of a switch.

The central information display is located in the center of the instrument panel above the ventilation outlet.



CID Control Panel

The central information display is located in the center of the instrument panel below the ventilation outlet.

The functions presented in the CID can be controlled with the rotary push-button on the right and the menu key on the CID control panel.

Navigation Computer DVD

The navigation computer is located in the lockable compartment between the seats in the partition between the vehicle interior and luggage compartment. The navigation computer DVD incorporates the main functions for the navigation system and contains the following components:

- DVD drive for reading information of the digitized road maps on DVD or CD
- GPS receiver for determining position before start of journey
- Yaw rate sensor for calculating position while driving
- Powerful processor for fast calculation of data
- Memory modules for buffering data
- Interfaces for communication with other systems and evaluating sensor data
- Interfaces for outputting image data and voice information
- GPS aerial

GPS Aerial

The GPS aerial receives the signals from GPS satellites and transfers the data (degrees longitude, degrees latitude, Greenwich meantime (GMT)) to the GPS receiver in the navigation computer DVD for the purpose of calculating the position. This is of particular importance during initial or re-initialization of the system. These data are also read in during the restart procedure.

The GPS aerial is located in the middle of the roof frame behind the interior lamp.

Wheel Speed Sensor

The wheel speed sensor determines the rotary motion of the wheel. The information is routed to the ABS/DSC control unit and the corresponding distance calculated. The conditioned signal is then made available to the navigation computer. The ABS sensor at the rear left is used for the purpose of determining the speed signal.

Reverse Light Switch

With the aid of the reverse light switch, the navigation system detects whether reverse gear is engaged. On manual transmission vehicles, the reverse light switch is located in the manual gearbox. On automatic vehicles, the reverse signal comes from the selector lever switch.

Principle of Operation

The navigation computer DVD represents a further-development of the MK-3 computer. The computing capacity of the navigation computer DVD has been doubled (from previously 54 MHz to 108 MHz). Likewise, the capacity of the memory modules has been enlarged and a new flash module integrated to allow for considerably faster flashing (from previously 15.6 MIPS to 70.0 MIPS, million instructions per second).

The previous functions of the MK-3 computer have been fully adopted. Only the new or modified functions are outlined in the following section.

The following functions are new:

- Additional destination inputs
- More accurate calculation of arrival time
- Improved direction
- Improved map presentation on the CID
- New map presentations
- Digitized road maps on DVD

The following new destination inputs are possible:

- Direct input of border crossing points
- Address book extended to 100 entries (20)
- Storage of last 20 destinations (10)

More accurate calculation of arrival time

The expected time of arrival is calculated more accurately by including the average vehicle speed corresponding to the type of road.

For this purpose, the average speed of the last 7 minutes is stored corresponding to the type of road (highway, major trunk road, district road). Based on the selected route, the computer calculates the share of different types of road and the determined average speed so it can calculate the arrival time more accurately.

Improved Direction

When changing from one highway to another, the number of the new roadway is announced (voice information).

Improved Map Presentation on the CID

In future, the maps will be presented in up to 256 colors. The indicator for the current position has been enlarged.

New Map Presentations

The scaling of the maps has been extended to 1000 miles. The scales 200 miles, 500 miles and 1000 miles have been additionally introduced. As a result, all the USA can be shown on the display. The selected route is highlighted in white.

In addition, 3 maps can be shown in different scales.

The following scales can be presented:

- The scale bar on the display corresponds to 1000 miles
- The scale bar on the display corresponds to 500 miles
- The scale bar on the display corresponds to 200 miles

The 200 miles, 500 miles and 1000 miles scales can only be presented in connection with DVD maps. The previous CD maps only provide scales of up to 100 miles.

The map scales are selected in the "Settings" menu under "Announcement."

Digitized Maps on DVD

The navigation computer DVD is equipped with a DVD drive. The navigation computer DVD is retro-compatible and can be used in all MK-x systems. It can also read the previously used CDs.

Operation

The High navigation system is controlled by selecting the "GPS navigation" menu in the main menu of the central information display.

Basic settings are possible under the menu item "Settings" in the main menu to adapt the display to country specific requirements. The various settings can be carried out in the windows. The red markings correspond to the current settings.

With the "Screen" menu item in the Settings menu it is possible to switch between full and split screen.

As a result, it is possible to show the map and the navigation arrow simultaneously.

Navigation is represented with arrows while in split screen or using the OBC functions.

The mask for entering the destination is accessed after selecting the "GPS navigation" menu. A submenu is selected by pressing the rotary push-button on the CID control panel.

In the "Announcement" menu, the last voice announcement is repeated by pressing the button. By pressing the button for longer than 2 seconds, the announcement is deactivated or activated depending on the setting.

"Route Selection" Menu

Destination Input

By pressing the button, current directions are ended in the "Destination input" menu and the input mask is selected in order to enter a new destination.

New Route

It is possible to switch between map presentation mode and arrow presentation mode in the "Route map" menu.

Service Information

Conversion

The navigation computer DVD is retro-compatible for all MK-x systems. The following point must be observed when the navigation computer DVD is fitted in a vehicle with MK-1 system:

The GPS receiver must be disconnected as the navigation computer DVD features an integrated GPS receiver.

Diagnosis

Diagnosis of the navigation systems comprises the following features:

- Read identification
- Diagnosis enquiry, e.g. gyro value, wheel speed, eject button

Coding

Coding of the navigation systems comprises the following functions:

- Recoding a control unit
- Retrofitting a control unit

Car & key memory

No functions are available for the car & key memory.

Service Mode

Service mode in the High navigation system supplies information for system diagnosis.

Accessing Service Mode

The test functions can be selected via the "Settings" menu in the central information display. Proceed as follows:

- Terminal R active
- Select main menu
- Select "Settings" menu
- Press and hold rotary push-button for 8 seconds
- Select the required menu item from the list that now appears
- Confirm selected menu item with the rotary push-button

Switch off terminal R to end the test functions.

Service Mode Menu Chart

Menu	Submenu	Display
CID		SW-Status 03 HW-Status 02 Diag-Index 03 Bus-Index 01 Coding Index 01 Supplier 17
GPS	Version	Receiver 8.6 SW Date dd.mm.yy
	Status	Latitude Degrees/Min/Sec Longitude Degrees/Min/Sec Altitude Meters Date dd.mm.yy Time Hour:Min G Speed Meter/Sec Heading Degrees Rec-Start POS Pos-Src PDOP 1.8 HDOP 1.4 VDOP 2.2
	Tracking Info	CH 1 PRN 07 S/N 5.1 Visible Sat 08 Almanac Yes
Video Module		SW-Status 11 HW-Status 04 Diag-Index 02 Bus-Index 11 Coding Index 02 Supplier 09
Sensor Check		Wheel 835 RL Navi 835 RR Navi Satellites 05 GPS Status Position Known Gyro 2500 DIR Forward/Reverse
Telematics		VIN Last 7 Vehicle Type E85 Roadster Color Registration Number SMS Code Number D1 BMW Information ON/OFF Auto Emergency Call ON/OFF Initialization ON/OFF Sign-off ON/OFF

Service Mode Menu Chart

Menu	Display	Explanation
GPS/Status	G Speed Heading Rec-Start Pos-Src PDOP HDOP VDOP	Relative Vehicle Speed over the ground Direction of Travel Search/Track/Position Receiver Status Number of Satellites available for analysis Accuracy of calculated position < 8 Sufficient determination of position < 4 Very good determination of position
GPS/Tracking Info	CH PRN S/N Visible Sat Almanac	Channel Satellite Detection Better Reception = Higher Value The number of visible satellites, signals receivable depends on time of day and constellation Satellite Database, automatically loaded after 15 minutes.
Sensor Check	Wheel Satellites GPS Status Gyro Direction	ABS Sensors, pulses/minute, neg. when reversing Number of satellites currently received 07: 3 Satellites received, position possible 11: 2D Position Determined 12: 3D Position Determined +,-, 400: mV setpoint value, halted or driving straight ahead, >right-hand, <left-hand curve Reverse Signal Detection
Telematics	VIN Color D1 BMW Information Auto emergency Call Initialization Sign-Off	Vehicle Identification Number Color Code Telephone network/contact number Customer Specific Information Status ON/OFF Telematics service status ON/OFF Log out of telematics service



Classroom Exercise - Review Questions

1. What is the procedure for radio removal on vehicles equipped with the CID?

2. In case of a malfunction what portions of the CID may be replaced separately?

3. Where is the aerial diversity unit located?

4. What is the location of the Top Hi-Fi amplifier?

5. Why does the Navigation system now use a DVD player?



Classroom Exercise - Review Questions

6. What is the location of the GPS aerial?

7. What is the additional wheel speed input used for on the navigation system?

8. What are some advantages of the Carver speaker system?
